

DC/DCコンバータ用トランス Transformer for DC/DC Converter

Mn-Zn type

RoHS

9EHH / 11EHH / 14EFH
13LFH / 17LDH / 19LDH / 25LDH
EE10.2 / EI12.5 / EE13 / SEE16 / EI22 / EE25
13LF / 17LC / 19LC / 25LA

特徴

- ・ 小型、各種電源用
- ・ 要求仕様に合わせた最適なトランス設計が可能
- ・ 多出力に対応可能
- ・ フォワード、フライバック方式に対応

Features

- ・ Compact and can be used for various power supplies
- ・ Designing best transformer based on specifications requested by customer available
- ・ Support multi-output
- ・ Can be used for Forward system and Flyback system



* 記載内容は、予告無く変更あるいは製造中止する場合があります。ご注文時は最新の情報をご確認願います。

* Any products mentioned in this catalog are subject to any modification or termination without prior notice. Please check a latest information at placing a purchase order.

* 記載製品のご使用に際しては、カタログ記載の『ご注意』をご確認願います。

* Please refer to "DIRECTIONS" in the catalog for proper use of the products.

■ 9EHH

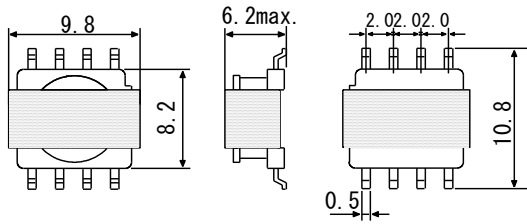

■ 11EHH

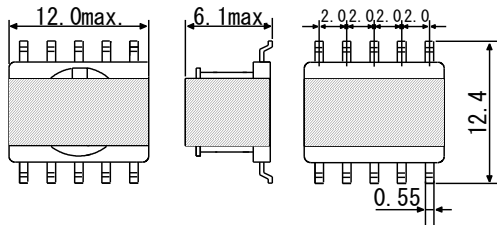

■ 14EFH

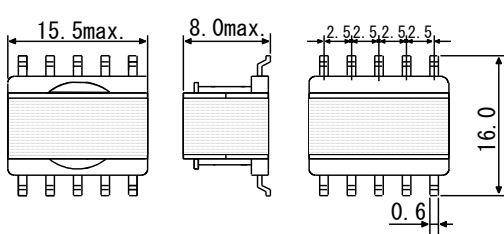

■ 13LFH to 25LDH

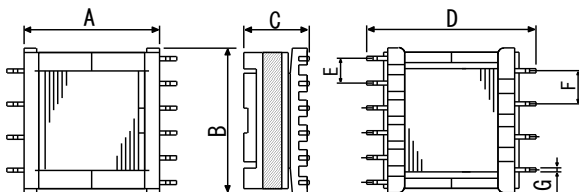

SAGAMI Type サガミタイプ	Dimensions(mm)							Pins ピン数
	A	B	C	D	E	F	G	
13LFH	14.0	14.0	8.8	19.8	3.0	3.0	0.7	10
17LDH	18.0	18.0	10.8	23.0	3.5	5.0	0.7	9
19LDH	20.5	20.0	10.8	25.0	3.5	5.0	0.7	10
25LDH	23.5	26.0	10.9	28.7	3.5	5.0	0.7	11



■ EE10.2 to EE25

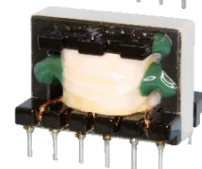
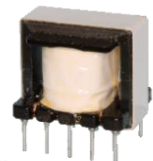
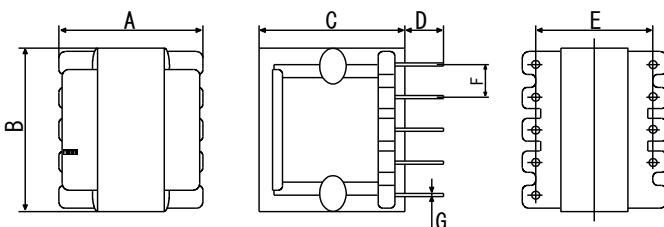

SAGAMI Type サガミタイプ	Dimensions(mm)							Pins ピン数
	A	B	C	D	E	F	G	
EE10.2	10.3	10.3	11.2	3.0	8.0	2.5	0.5	8
EI12.5	12.7	12.4	9.3	3.0	7.5	2.5	0.6	10
EE13	12.6	13.0	12.7	3.0	8.5	2.5	0.6	10
SEE16	14.0	16.0	14.9	4.0	11.0	3.3	0.6	10
SEE19	18.8	19.2	16.7	4.5	15.0	4.0	0.7	10
EE22	17.0	22.8	20.6	6.0	12.5	5.0	0.6	8
EE25	17.7	25.3	20.0	4.5	12.5	5.0	0.8	8



* 記載内容は、予告無く変更あるいは製造中止する場合があります。ご注文時は最新の情報をご確認願います。

* Any products mentioned in this catalog are subject to any modification or termination without prior notice. Please check a latest information at placing a purchase order.

* 記載製品のご使用に際しては、カタログ記載の『ご注意』をご確認願います。

* Please refer to " DIRECTIONS " in the catalog for proper use of the products.

■ 13LF to 25LA

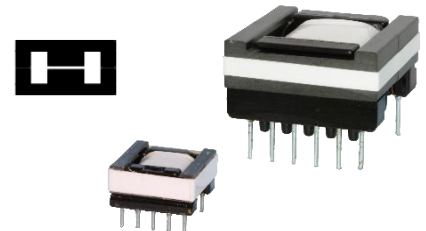
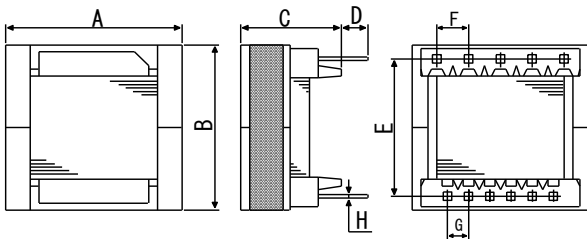

SAGAMI Type サガミタイプ	Dimensions(mm)								Pins ピン数
	A	B	C	D	E	F	G	H	
13LF	13.8	14.0	7.8	2.5	10.5	2.5	2.5	0.49	10
17LC	18.0	18.0	12.0	4.5	15.0	3.75	2.5	0.5	10
19LC	19.7	20.2	12.0	4.5	16.25	3.75	2.5	0.5	11
25LA	25.6	25.8	16.2	4.5	20.0	5.0	3.75	0.8	11

Selection Guide

Type タイプ	Appearance 形状		Maximum output power (reference) 最大出力電力(参考) (W)			Input voltage range 入力電圧範囲 (V)	Output voltage range 出力電圧範囲 (V)		Operating frequency 動作周波数 (kHz)		Output Channels 出力数 reference 参考
			Conditions 条件								
			(A)	(B)	(C)						
9EHH	ER9.5/5	SMD	2.3	1.1	2.8	0.7~18	30	Max.	1000	Max.	3
11EHH	ER11/5	SMD	3.0	1.5	3.4	0.7~24	130	Max.	1000	Max.	5
14EFH	ER14.5/6	SMD	5.4	2.7	5.0	0.7~35	150	Max.	1000	Max.	5
13LFH	EPC13	SMD	4.8	2.4	5.4	0.7~35	130	Max.	500	Max.	5
17LDH	EPC17	SMD	12.0	6.0	10.1	0.7~50	150	Max.	500	Max.	6
19LDH	EPC19	SMD	16.2	8.1	13.6	0.7~50	150	Max.	500	Max.	6
25LDH	EPC25	SMD	27.0	13.5	22.1	0.7~50	150	Max.	500	Max.	6
EE10.2	10.2	PIN	5.6	2.8		0.7~24	80	Max.	200	Max.	5
EI12.5	12.5	PIN	5.3	2.6		0.7~24	80	Max.	200	Max.	6
EE13	13	PIN	10.2	5.1		0.7~35	150	Max.	500	Max.	6
SEE16	16	PIN	19.2	9.6		0.7~35	150	Max.	500	Max.	6
SEE19	19	PIN	36.0	18.0		0.9~50	150	Max.	300	Max.	6
EI22	22	PIN	19.8	9.9		0.9~50	150	Max.	300	Max.	5
EE25	25	PIN	42.0	21.0		0.9~50	150	Max.	300	Max.	5
13LF	EPC13	PIN	4.8	2.4	5.4	0.7~35	130	Max.	500	Max.	5
17LC	EPC17	PIN	12.0	6.0	10.1	0.7~50	150	Max.	500	Max.	5
19LC	EPC19	PIN	16.2	8.1	13.6	0.7~50	150	Max.	500	Max.	6
25LA	EPC25	PIN	35.4	17.7	29.1	0.7~50	150	Max.	500	Max.	6

上記最大出力の目安は、選択された回路や採用される部品等により変わります。

コアの材質は、通常の低損失材では、500kHzが上限となります。

300kHz以上の動作は、材質を変えての対応となります。

The above mentioned maximum output powers vary depending on the selected circuits, components, and so on.

The upper limit of the core materials is 500kHz in case of the regular low loss materials. The core materials shall be changed

for the operations exceeding 300kHz. The temperature rise shall change significantly depending on the utility factors.

Item 項目	Circuits 回路		
	(A)	(B)	(C)
Core materials コア材質	Low loss 低損失材		High-frequency 高周波材
Circuits 回路	Fly-back フライバック		
Frequency 周波数	100kHz	100kHz	500kHz
Temperature rise 温度上昇	40°C	20°C	



* 記載内容は、予告無く変更あるいは製造中止する場合があります。ご注文時は最新の情報をご確認願います。

* Any products mentioned in this catalog are subject to any modification or termination without prior notice. Please check a latest information at placing a purchase order.

* 記載製品のご使用に際しては、カタログ記載の『ご注意』をご確認願います。

* Please refer to " DIRECTIONS " in the catalog for proper use of the products.

Example circuit(3)

車載用機器・モバイル機器電源(SEPIC回路)
Power Supply for Automotive Equipment & Mobile Equipment
(SEPIC Circuit)

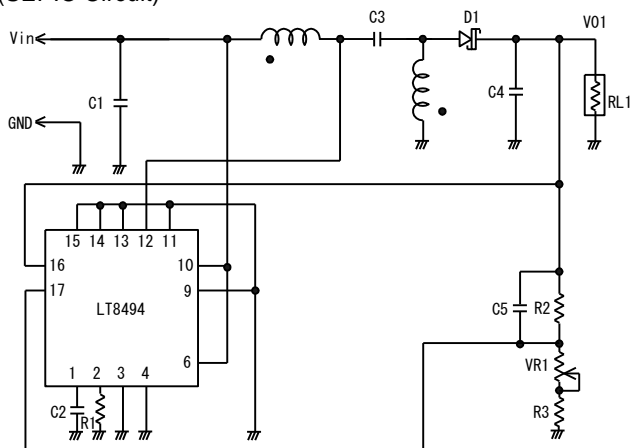

Example circuit(4)

車載用機器・モバイル機器電源(ZETA回路)
Power Supply for Automotive Equipment & Mobile Equipment
(ZETA Circuit)

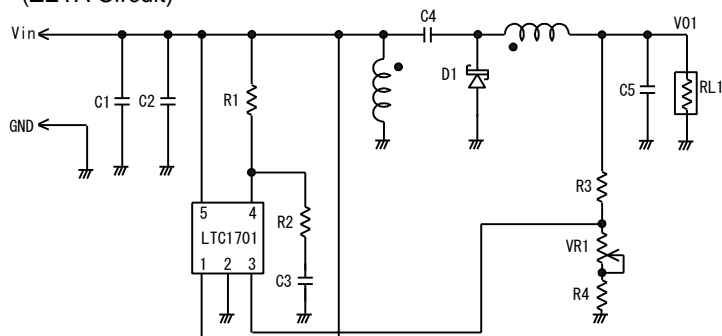

Example circuit(5)

蛍光表示管用電源(他励式フライバック回路 DC+AC出力)
Power Supply for Fluorescent Character Display Tube (Externally Commutated Fly-back Circuit DC+AC Output)

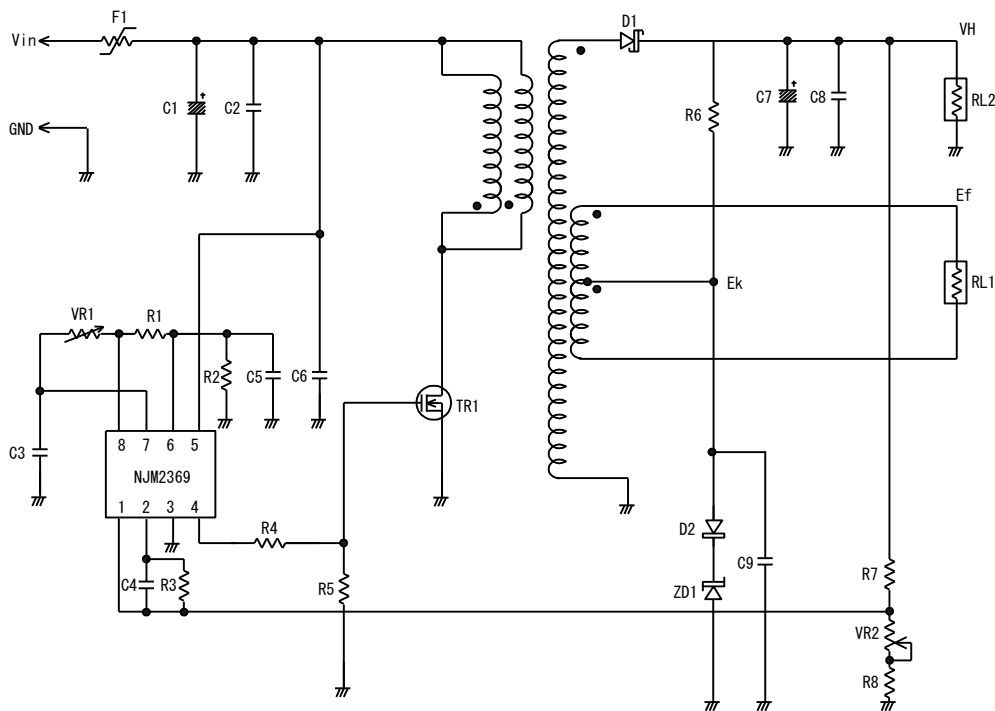

* 記載内容は、予告無く変更あるいは製造中止する場合があります。ご注文時は最新の情報をご確認願います。
* Any products mentioned in this catalog are subject to any modification or termination without prior notice. Please check a latest information at placing a purchase order.
* 記載製品のご使用に際しては、カタログ記載の『ご注意』をご確認願います。
* Please refer to "DIRECTIONS" in the catalog for proper use of the products.

Example circuit(6)

蛍光表示管用電源(自励式フライバック回路 DC+AC出力)

Power Supply for Fluorescent Character Display Tube (Self-Commutated Fly-back Circuit DC+AC Output)

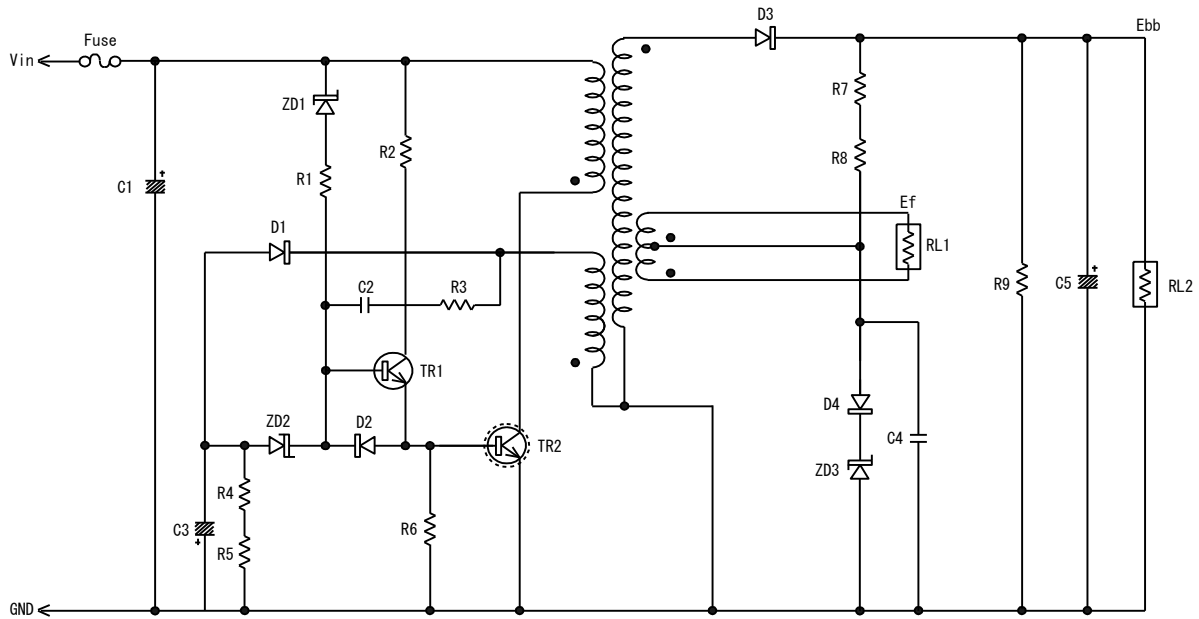

Example circuit(7)

蛍光表示管用電源(ロイヤール回路 DC+AC出力)

Power Supply for Fluorescent Character Display Tube (Royer's Circuit DC+AC Output)

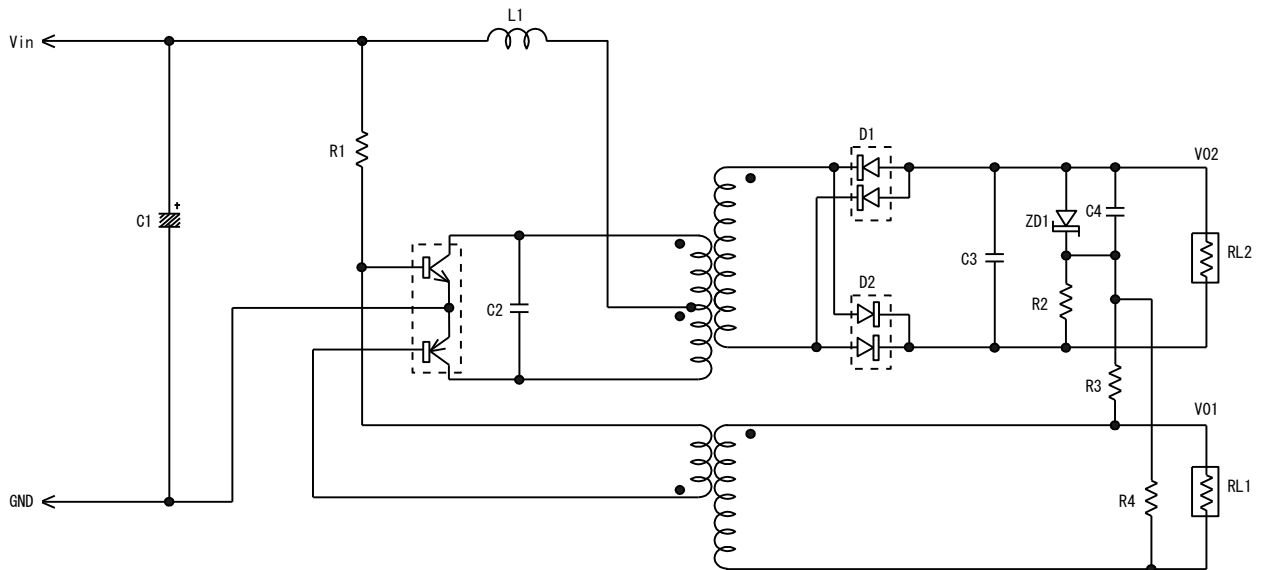

* 記載内容は、予告無く変更あるいは製造中止する場合があります。ご注文時は最新の情報をご確認願います。

* Any products mentioned in this catalog are subject to any modification or termination without prior notice. Please check a latest information at placing a purchase order.

* 記載製品のご使用に際しては、カタログ記載の『ご注意』をご確認願います。

* Please refer to " DIRECTIONS " in the catalog for proper use of the products.