

CBE1914HS

New Products

RoHS

AEC-Q200

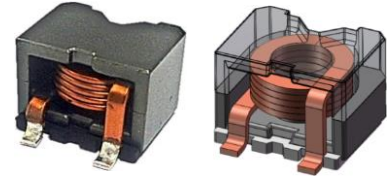

■ Features

- Power inductor with greatly improved current characteristics
- Closed magnetic circuit structure with low leakage flux
- Uses flat wire, low resistance and high current specifications
- Construction for high current

■ Magnetic structure



Operating Temperature Range : -40 °C~ +150 °C(include self-heating)

Weight : 16.0 g

■ Application

- Electronic devices for Vehicle
- For DC/DC converter
- For Noise Filter

■ Dimensions

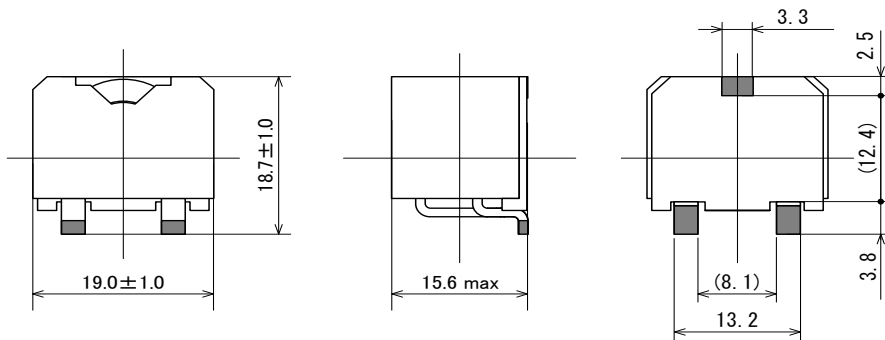

(Unit : mm)

■ Recommended Land Pattern

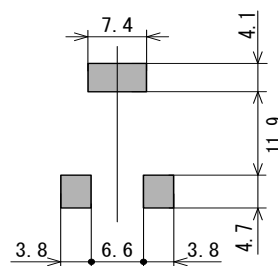

(Unit : mm)



SAGAMI ELEC CO., LTD.
<https://www.sagami-elec.co.jp>

10-30, Ichibashimo-cho, Tsurumi-ku, Yokohama, Kanagawa 230-0024, Japan
 Over Seas Sales Dept. TEL : +81 45 511 3141, E-mail : ossg@sagami-elec.co.jp
 Engineering Dept. TEL : +81 45 521 4543

⚠ The contents of this catalogue are subject to change without notice.

■ Specifications

SAGAMI Part No.	Inductance (μ H)	DCR Resistance (m Ω) max.	Rated current	
			DC saturation allowable current (A)	Temperature rise allowable current (A)
CBE1914HS-1R0M	1.0 \pm 20%	2.20	95.0	31.0
CBE1914HS-2R0M	2.0 \pm 20%	2.20	60.0	31.0
CBE1914HS-4R0M	4.0 \pm 20%	2.20	31.0	31.0
CBE1914HS-4R7M	4.7 \pm 20%	2.20	24.0	31.0
CBE1914HS-100M	10 \pm 20%	5.60	21.0	19.0
-	-	-	-	-
-	-	-	-	-
-	-	-	-	-
-	-	-	-	-
-	-	-	-	-

- Inductance Measuring Condition : 100kHz,1V
- Rated current : DC saturation allowable current or Temperature rise allowable current, whichever is smaller.
 1. DC saturation allowable current : value of inductance decrease 10%.
 2. Temperature rise allowable current : A rise in temperature of core surface is 40°C.

■ Characteristics of DC Saturation Current

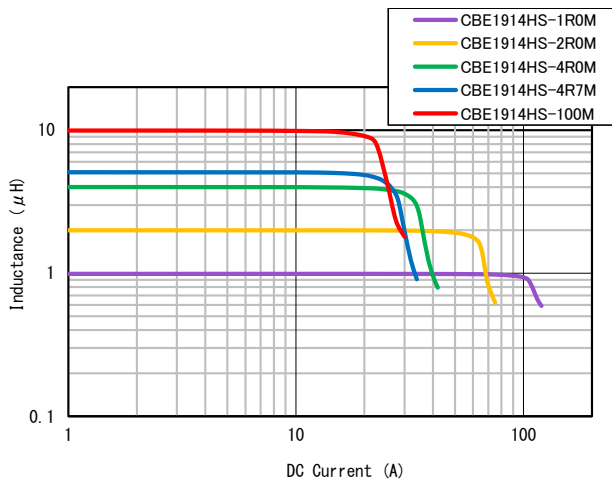

■ Characteristics of Temperature rise

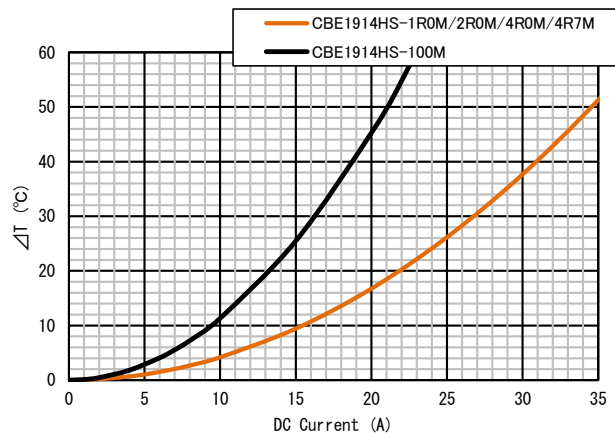

SAGAMI ELEC CO., LTD.
<https://www.sagami-elec.co.jp>

10-30, Ichibashimo-cho, Tsurumi-ku, Yokohama, Kanagawa 230-0024, Japan
 Over Seas Sales Dept. TEL : +81 45 511 3141, E-mail : ossg@sagami-elec.co.jp
 Engineering Dept. TEL : +81 45 521 4543

⚠ The contents of this catalogue are subject to change without notice.