

高温対応・車載対応

High temperature environments grade, Automotive grade

デュアルインダクタ

Dual Inductors

## SQR series

RoHS

AEC-Q200

SQR8042C / SQR8065C

SQR1042C / SQR1065C

SQR1242C / SQR1257C/SQR1277C

SQR8042CA / SQR8065CA

SQR1277CA

セピックコンバータ/SEPIC Converter

### 特長

- ・2巻線を1パッケージ(2in1構造)で対応したパワーインダクタ
- ・SEPIC、ZETAコンバータ、フライバックコンバータなどに対応
- ・閉磁路構造、大電流対応
- ・AEC-Q200に対応
- ・動作温度範囲：-40℃～+125℃（自己発熱を含む）
- ・外形ごとに高さ4.5mm、6.0mm、6.8mm、8.0mm品より選択可能
- ・SQR-CAシリーズは、極性を同一方向に合わせた仕様

### Features

- ・ Power Inductor by "Two Windings in One Package(2-in-1 structure)"
- ・ Can be used for SEPIC, ZETA converter, Flyback converter and so on
- ・ Magnetically Shielded structure, Support High-currents
- ・ AEC-Q200 compliant
- ・ Operating Temperature:-40℃～+125℃(Including Self-heating)
- ・ Height is selectable for outline size:4.5mm, 6.0mm, 6.8mm, or 8.0mm
- ・ SQR-CA series specs : Polarity aligned in one direction



## ■ SQR80-C/CA series

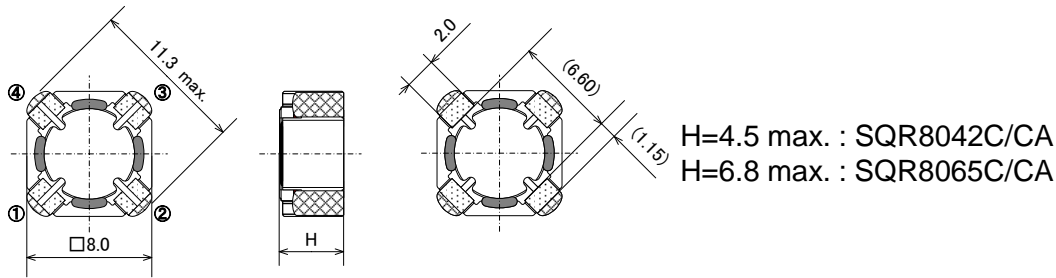

## ■ SQR10-C series

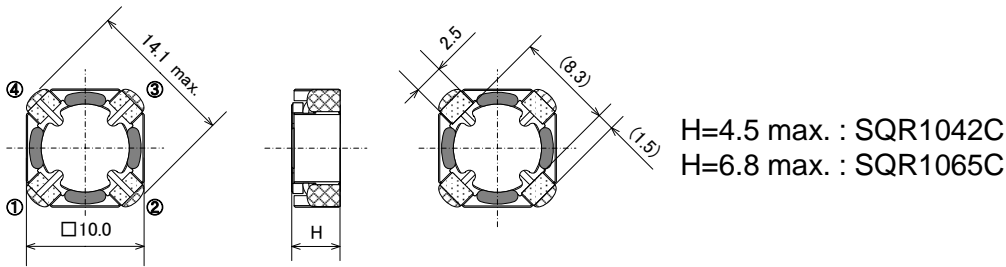

## ■ SQR12-C/CA series

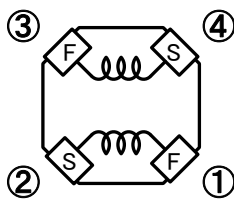
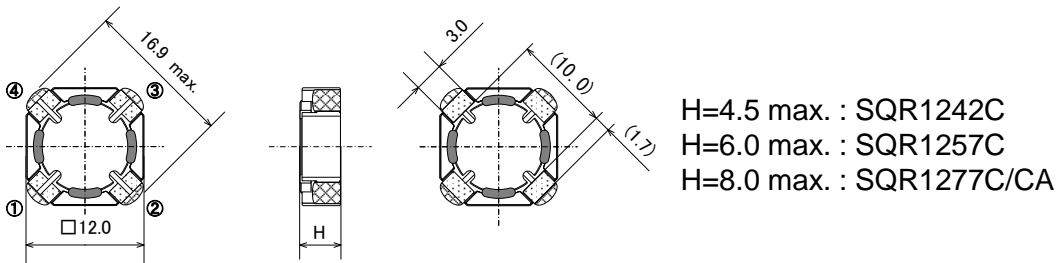

CONNECTION  
(SQR-C series)

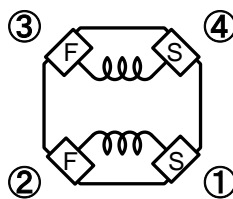

CONNECTION  
(SQR-CA series)

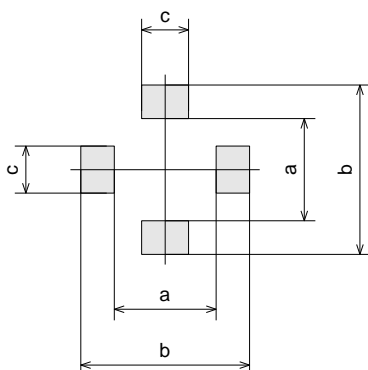
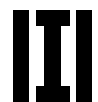

Recommended Land Pattern 推奨ランドパターン

Type	a	b	c
SQR80 series	6.1	10.1	2.8
SQR10 series	7.2	13.1	2.8
SQR12 series	8.7	15.8	3.3



\* 記載内容は、予告無く変更あるいは製造中止する場合があります。ご注文時は最新の情報をご確認願います。  
 \* Any products mentioned in this catalog are subject to any modification or termination without prior notice. Please check a latest information at placing a purchase order.  
 \* 記載製品のご使用に際しては、カタログ記載の『注意』をご確認願います。  
 \* Please refer to " DIRECTIONS " in the catalog for proper use of the products.

## ■ SQR80-C series

Code	Inductance ( $\mu\text{H}$ )	DC Resistance 直流抵抗 ( $\Omega$ ) $\pm 30\%$				DC saturation allowable current 直流重畳許容電流 (A)		Temperature rise allowable current 温度上昇許容電流 (A)			
		SQR8042C		SQR8065C		SQR8042C	SQR8065C	SQR8042C		SQR8065C	
		④-③	②-①	④-③	②-①			※1	※2	※1	※2
1R0	1.0	0.010	0.012			6.30		4.25	3.30		
1R2	1.2			0.011	0.012		8.00			4.50	3.35
1R5	1.5	0.014	0.017	0.013	0.014	5.10	6.55	3.60	2.80	4.00	3.05
2R2	2.2	0.018	0.022	0.015	0.017	4.35	5.50	3.05	2.45	3.70	2.80
2R7	2.7	0.023	0.029			3.85		2.75	2.10		
3R0	3.0			0.020	0.022		4.75			3.20	2.45
3R6	3.6			0.022	0.025		4.15			3.00	2.30
3R9	3.9	0.026	0.033			3.40		2.50	1.85		
4R3	4.3			0.025	0.029		3.85			2.80	2.15
4R7	4.7	0.035	0.043			3.05		2.20	1.70		
5R6	5.6	0.040	0.050	0.030	0.035	2.80	3.45	2.05	1.55	2.50	1.95
6R2	6.2			0.033	0.039		3.10			2.30	1.85
6R8	6.8	0.047	0.059			2.55		1.95	1.45		
7R5	7.5			0.041	0.048		3.00			2.10	1.65
8R2	8.2	0.056	0.069			2.35		1.70	1.35		
9R1	9.1			0.044	0.052		2.75			2.00	1.55
100	10	0.06	0.076	0.047	0.057	2.20	2.55	1.55	1.20	1.95	1.50
120	12	0.075	0.096	0.059	0.070	1.90	2.40	1.45	1.10	1.75	1.35
150	15	0.094	0.120	0.067	0.081	1.70	2.05	1.30	1.00	1.65	1.25
180	18	0.11	0.140	0.079	0.096	1.60	1.85	1.20	0.90	1.50	1.15
220	22	0.14	0.17	0.094	0.110	1.45	1.70	1.05	0.80	1.35	1.05
270	27	0.16	0.21	0.11	0.140	1.30	1.60	0.95	0.73	1.25	0.95
330	33	0.21	0.27	0.14	0.17	1.15	1.40	0.85	0.65	1.10	0.85
390	39	0.24	0.31	0.16	0.20	1.05	1.30	0.75	0.60	1.05	0.80
470	47	0.31	0.39	0.20	0.24	0.95	1.15	0.70	0.55	0.95	0.73
560	56			0.24	0.30		1.05			0.85	0.65
680	68			0.30	0.36		1.00			0.75	0.60
820	82			0.36	0.44		0.90			0.68	0.53
101	100			0.45	0.54		0.80			0.62	0.48
121	120			0.48	0.59		0.75			0.59	0.46
151	150			0.63	0.77		0.65			0.52	0.40

Notes: 1. Measurement Frequency for Inductance: 100kHz  
 2. DC saturation allowable current: Value of inductance decrease within 30%  
 3. Temperature rise allowable current: A rise in temperature of core surface is within 40°C  
 ※1. 4-3 or 2-1  
 ※2. 4-1 (3-2 short)

記事: 1. インダクタンス測定周波数: 100kHz  
 2. 直流重畳許容電流: インダクタンスの減少が30%以内の電流値  
 3. 温度上昇許容電流: コアの表面温度上昇が40°C以下の電流値  
 ※1: ④-③間 or ②-①間  
 ※2: ④-①間 (③-②間 ショート)

セピックコンバータ/SEPIC Converter

### Inductance Range インダクタンス範囲

Tolerance	SQR8042C	SQR8065C
±30%(N)	1.0~8.2 $\mu\text{H}$	1.2~9.1 $\mu\text{H}$
±20%(M)	10~47 $\mu\text{H}$	10~150 $\mu\text{H}$

### Parts Code 品番コード例

SQR8042C	-	100	M
Type タイプ		Inductance Code インダクタンスコード	Tolerance 許容差



## ■ SQR80-C series

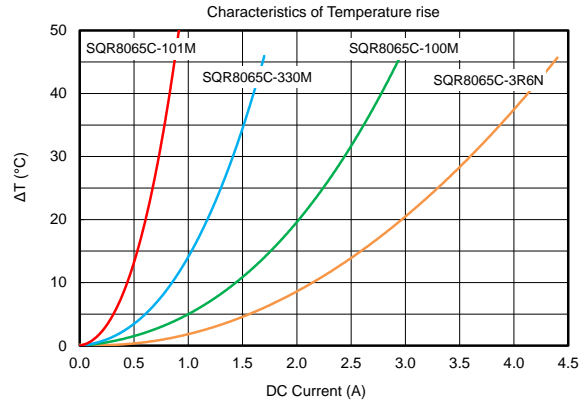
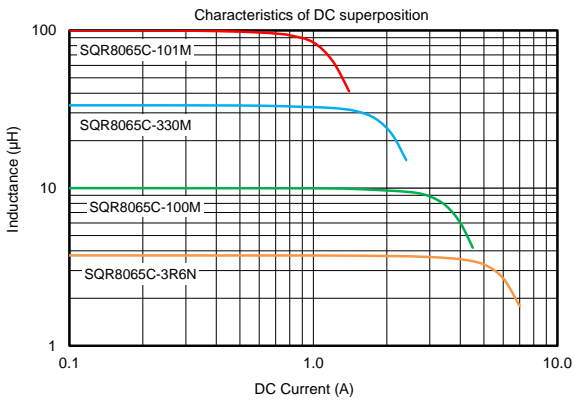
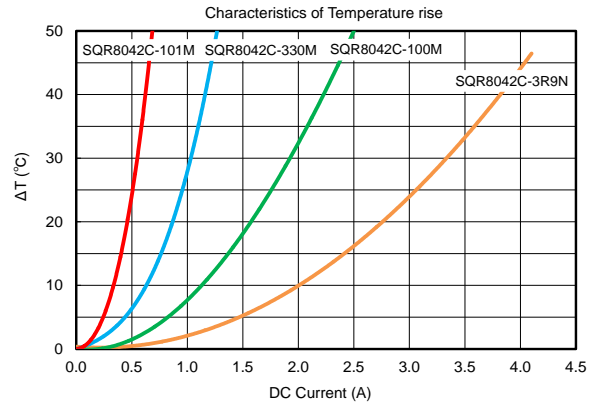
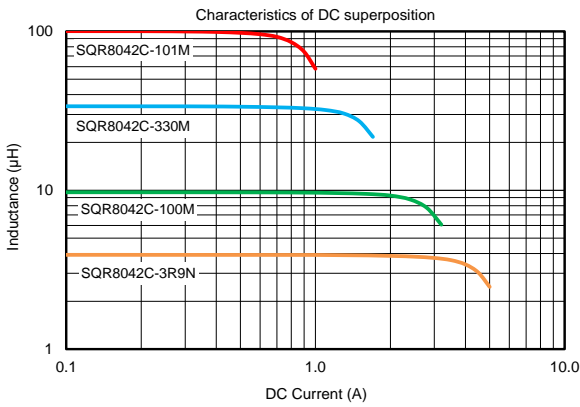

Notes: Graphs are based on typical values of each type, not specific values.

記事: 特性グラフは各タイプの代表値を基に作成しています。規格値ではありません。



\* 記載内容は、予告無く変更あるいは製造中止する場合があります。ご注文時は最新の情報をご確認願います。  
 \* Any products mentioned in this catalog are subject to any modification or termination without prior notice. Please check a latest information at placing a purchase order.  
 \* 記載製品のご使用に際しては、カタログ記載の『注意』をご確認願います。  
 \* Please refer to " DIRECTIONS " in the catalog for proper use of the products.

## ■ SQR10-C series

Code	Inductance ( $\mu\text{H}$ )	DC Resistance 直流抵抗 ( $\Omega$ ) $\pm 30\%$				DC saturation allowable current 直流重畳許容電流 (A)		Temperature rise allowable current 温度上昇許容電流 (A)			
		SQR1042C ④-③ ②-①		SQR1065C ④-③ ②-①		SQR1042C	SQR1065C	SQR1042C ※1 ※2		SQR1065C ※1 ※2	
1R5	1.5	0.009	0.011	0.009	0.010	8.15	11.80	4.30	3.30	5.05	3.65
2R0	2.0			0.011	0.012		10.20			4.65	3.35
2R2	2.2	0.012	0.015			6.70		3.75	2.85		
2R7	2.7			0.014	0.016		8.60			3.85	2.85
3R0	3.0	0.016	0.020			5.85		3.35	2.50		
3R6	3.6			0.018	0.020		7.60			3.50	2.60
3R9	3.9	0.020	0.026			5.05		2.85	2.15		
4R7	4.7			0.023	0.027		6.60			2.95	2.20
5R1	5.1	0.027	0.034			4.45		2.50	1.90		
5R6	5.6			0.026	0.030		6.00			2.75	2.05
6R2	6.2	0.030	0.039			4.00		2.35	1.70		
6R8	6.8			0.031	0.037		5.35			2.50	1.85
7R5	7.5	0.042	0.052			3.55		2.00	1.50		
8R2	8.2			0.040	0.046		4.95			2.25	1.70
9R1	9.1	0.046	0.058			3.35		1.90	1.40		
100	10	0.050	0.064	0.044	0.051	3.00	4.60	1.80	1.30	2.10	1.60
120	12	0.062	0.079	0.048	0.056	2.75	4.25	1.60	1.20	2.00	1.50
150	15	0.072	0.088	0.062	0.073	2.55	3.65	1.50	1.10	1.75	1.30
180	18	0.096	0.120	0.075	0.088	2.30	3.35	1.35	1.00	1.65	1.20
220	22	0.12	0.150	0.084	0.100	2.00	3.10	1.15	0.90	1.50	1.10
270	27	0.14	0.18	0.11	0.130	1.85	2.80	1.05	0.80	1.35	1.00
330	33	0.17	0.22	0.13	0.150	1.60	2.50	0.95	0.73	1.25	0.93
390	39	0.21	0.27	0.15	0.18	1.50	2.35	0.85	0.65	1.13	0.85
470	47	0.25	0.31	0.20	0.23	1.40	2.00	0.80	0.60	0.98	0.75
560	56	0.31	0.40	0.23	0.27	1.25	1.90	0.70	0.55	0.90	0.67
680	68	0.38	0.48	0.28	0.32	1.15	1.75	0.65	0.49	0.82	0.62
820	82	0.42	0.54	0.33	0.37	1.05	1.60	0.63	0.46	0.74	0.57
101	100	0.53	0.67	0.42	0.49	0.95	1.45	0.55	0.41	0.65	0.49
121	120			0.47	0.56		1.30			0.62	0.47
151	150			0.60	0.71		1.15			0.55	0.41
181	180			0.72	0.85		1.05			0.50	0.37
221	220			0.91	1.08		0.95			0.44	0.33

Notes: 1. Measurement Frequency for Inductance: 100kHz  
 2. DC saturation allowable current: Value of inductance decrease within 30%  
 3. Temperature rise allowable current: A rise in temperature of core surface is within 40°C  
 ※1. 4-3 or 2-1  
 ※2. 4-1 (3-2 short)

記事: 1. インダクタンス測定周波数: 100kHz  
 2. 直流重畳許容電流: インダクタンスの減少が30%以内の電流値  
 3. 温度上昇許容電流: コアの表面温度上昇が40°C以下の電流値  
 ※1: ④-③間 or ②-①間  
 ※2: ④-①間 (③-②間 ショート)

セピックコンバータ/SEPIC Converter

### Inductance Range インダクタンス範囲

Tolerance	SQR1042C	SQR1065C
$\pm 30\%$ (N)	1.5~9.1 $\mu\text{H}$	1.5~8.2 $\mu\text{H}$
$\pm 20\%$ (M)	10~100 $\mu\text{H}$	10~220 $\mu\text{H}$

### Parts Code 品番コード例

SQR1042C	-	100	M
Type タイプ		Inductance Code インダクタンスコード	Tolerance 許容差



## ■ SQR10-C series

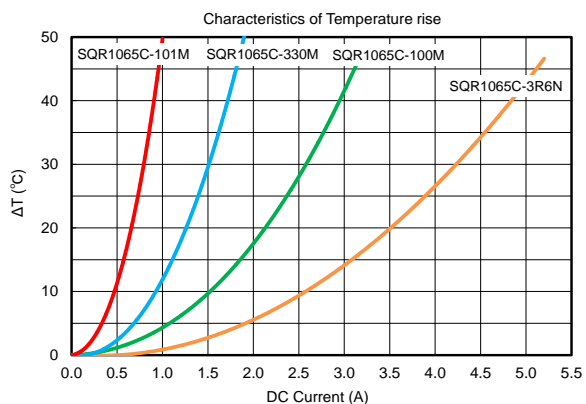
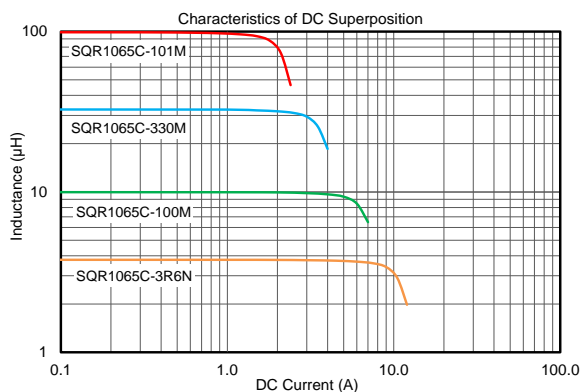
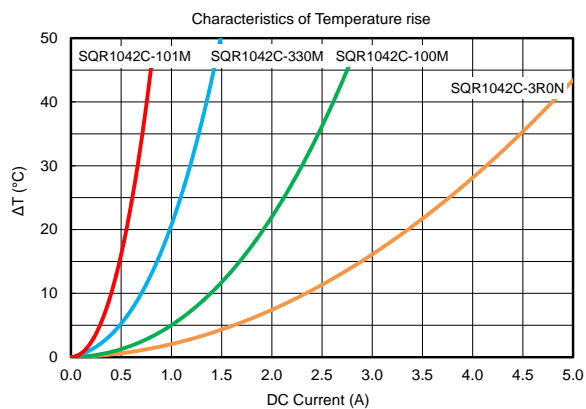
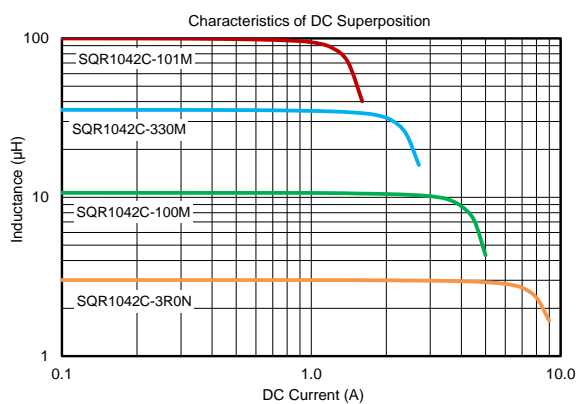

Notes: Graphs are based on typical values of each type, not specific values.

記事: 特性グラフは各タイプの代表値を基に作成しています。規格値ではありません。



\* 記載内容は、予告無く変更あるいは製造中止する場合があります。ご注文時は最新の情報をご確認願います。  
 \* Any products mentioned in this catalog are subject to any modification or termination without prior notice. Please check a latest information at placing a purchase order.  
 \* 記載製品のご使用に際しては、カタログ記載の『注意』をご確認願います。  
 \* Please refer to " DIRECTIONS " in the catalog for proper use of the products.

## ■ SQR12-C series

Code	Inductance インダクタンス ( $\mu\text{H}$ )	DC Resistance 直流抵抗 ( $\Omega$ ) $\pm 30\%$						DC saturation allowable current 直流重畳許容電流 (A)			Temperature rise allowable current 温度上昇許容電流 (A)					
		SQR1242C ④-③ ②-①		SQR1257C ④-③ ②-①		SQR1277C ④-③ ②-①		SQR 1242C	SQR 1257C	SQR 1277C	SQR1242C ※1 ※2		SQR1257C ※1 ※2		SQR1277C ※1 ※2	
1R2	1.2	0.008	0.009	0.008	0.009			12.50	15.40		4.85	3.75	5.40	3.80		
2R0	2.0	0.011	0.014	0.010	0.011	0.011	0.012	9.90	12.10	14.70	4.20	3.15	4.90	3.50	4.90	3.65
2R7	2.7	0.014	0.018	0.012	0.014	0.013	0.014	8.05	10.00	11.90	3.65	2.80	4.40	3.20	4.40	3.30
3R9	3.9	0.020	0.025	0.016	0.019	0.015	0.017	6.90	8.55	10.00	3.20	2.35	3.90	2.75	4.05	3.05
5R1	5.1	0.025	0.031	0.020	0.023	0.017	0.020	6.10	7.50	9.00	2.75	2.10	3.35	2.50	3.70	2.85
6R2	6.2			0.023	0.027				6.60				3.10	2.40		
6R8	6.8	0.033	0.041			0.022	0.025	5.30		7.90	2.45	1.83			3.25	2.50
8R2	8.2	0.041	0.052	0.029	0.035	0.025	0.028	4.80	5.80	6.95	2.15	1.60	2.75	2.00	3.05	2.35
100	10.0	0.052	0.064	0.036	0.042	0.027	0.032	4.25	5.35	6.30	2.00	1.48	2.55	1.80	2.90	2.25
120	12.0	0.058	0.072	0.046	0.054	0.032	0.037	4.05	4.95	5.75	1.80	1.35	2.20	1.60	2.65	2.05
150	15	0.079	0.100	0.054	0.064	0.045	0.052	3.40	4.15	5.00	1.55	1.18	2.00	1.45	2.25	1.75
180	18	0.090	0.110	0.065	0.077	0.053	0.061	3.10	3.75	4.60	1.45	1.10	1.80	1.35	2.10	1.58
220	22	0.100	0.130	0.085	0.100	0.067	0.076	2.95	3.40	4.35	1.35	1.03	1.60	1.20	1.85	1.40
270	27	0.130	0.160	0.090	0.110	0.076	0.087	2.50	3.25	3.85	1.20	0.90	1.50	1.10	1.70	1.30
330	33	0.160	0.200	0.120	0.140	0.095	0.110	2.25	2.80	3.35	1.05	0.80	1.40	1.05	1.55	1.15
390	39	0.190	0.240	0.140	0.160	0.120	0.140	2.10	2.60	3.05	0.95	0.73	1.25	0.91	1.35	1.03
470	47	0.220	0.280	0.160	0.190	0.130	0.150	1.90	2.35	2.90	0.85	0.65	1.15	0.83	1.30	0.98
560	56	0.280	0.350	0.190	0.230	0.160	0.190	1.80	2.20	2.70	0.80	0.60	1.05	0.77	1.15	0.87
680	68	0.330	0.420	0.240	0.280	0.200	0.230	1.60	1.90	2.35	0.73	0.55	0.92	0.69	1.05	0.79
820	82	0.410	0.510	0.270	0.330	0.230	0.270	1.53	1.80	2.10	0.65	0.49	0.85	0.64	0.96	0.72
101	100	0.510	0.640	0.340	0.410	0.280	0.320	1.33	1.55	1.95	0.60	0.44	0.75	0.55	0.88	0.66
121	120	0.610	0.740	0.420	0.510	0.340	0.390	1.20	1.45	1.80	0.55	0.40	0.68	0.51	0.80	0.60
151	150			0.520	0.63	0.420	0.480		1.35	1.55			0.61	0.46	0.72	0.53
181	180			0.650	0.79	0.500	0.580		1.25	1.45			0.54	0.42	0.68	0.49
221	220			0.840	1.01	0.620	0.720		1.05	1.35			0.47	0.36	0.58	0.43
271	270			1.00	1.20	0.750	0.870		1.00	1.15			0.43	0.33	0.53	0.39
331	330			1.10	1.35	0.950	1.10		0.90	1.10			0.40	0.30	0.45	0.34
391	390					1.14	1.32			0.95				0.43	0.31	
471	470					1.26	1.48			0.85				0.40	0.30	
561	560					1.57	1.83			0.80				0.36	0.27	

Notes: 1. Measurement Frequency for Inductance: 100kHz  
 2. DC saturation allowable current: Value of inductance decrease within 30%  
 3. Temperature rise allowable current: A rise in temperature of core surface is within 40°C  
 ※1. 4-3 or 2-1  
 ※2. 4-1 (3-2 short)

記事: 1. インダクタンス測定周波数: 100kHz  
 2. 直流重畳許容電流: インダクタンスの減少が30%以内の電流値  
 3. 温度上昇許容電流: コアの表面温度上昇が40°C以下の電流値  
 ※1: ④-③間 or ②-①間  
 ※2: ④-①間 (③-②間 ショート)

セピクコンバータ/SEPIC Converter

Inductance Range インダクタンス範囲

Tolerance	SQR1242C	SQR1257C	SQR1277C
$\pm 30\%$ (N)	1.2~8.2 $\mu\text{H}$	1.2~8.2 $\mu\text{H}$	2.0~8.2 $\mu\text{H}$
$\pm 20\%$ (M)	10~120 $\mu\text{H}$	10~330 $\mu\text{H}$	10~560 $\mu\text{H}$

Parts Code 品番コード例

SQR1242C	—	100	M
Type タイプ		Inductance Code インダクタンスコード	Tolerance 許容差



## ■ SQR12-C series

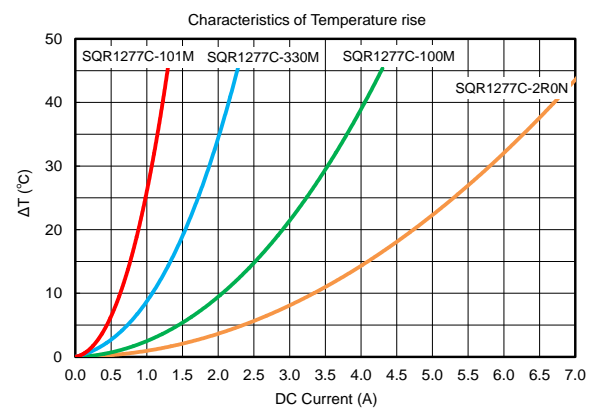
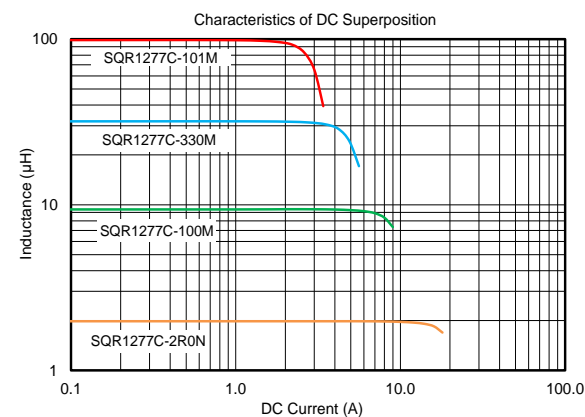
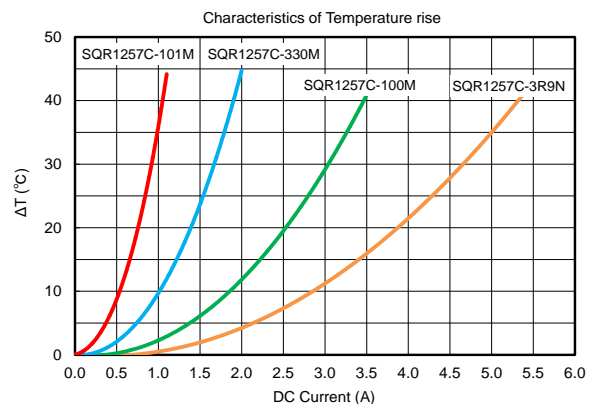
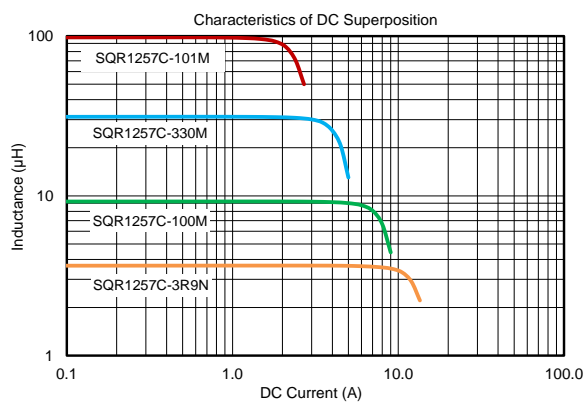
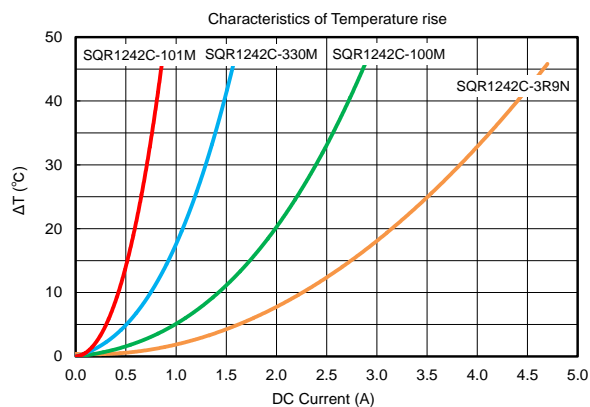
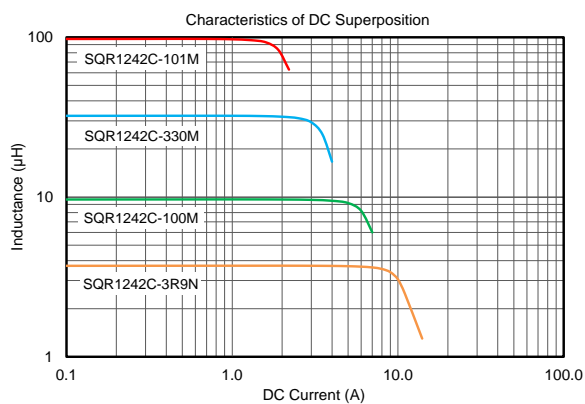

Notes: Graphs are based on typical values of each type, not specific values.

記事: 特性グラフは各タイプの代表値を基に作成しています。規格値ではありません。



\* 記載内容は、予告無く変更あるいは製造中止する場合があります。ご注文時は最新の情報をご確認願います。  
 \* Any products mentioned in this catalog are subject to any modification or termination without prior notice. Please check a latest information at placing a purchase order.  
 \* 記載製品のご使用に際しては、カタログ記載の『注意』をご確認願います。  
 \* Please refer to " DIRECTIONS " in the catalog for proper use of the products.



## ■ SQR80/12-CA series

Code	Inductance ( $\mu\text{H}$ )	DC Resistance 直流抵抗 ( $\Omega$ ) max.				DC saturation allowable current 直流重畳許容電流 (A)			Temperature rise allowable current 温度上昇許容電流 (A)							
		SQR8042CA ④-③ ②-①		SQR8065CA ④-③ ②-①		SQR1277CA ④-③ ②-①		SQR 8042CA	SQR 8065CA	SQR 1277CA	SQR8042CA ※1 ※2		SQR8065CA ※1 ※2		SQR1277CA ※1 ※2	
1R3	1.3	0.017	0.017	0.016	0.016			6.30	7.65		3.85	3.15	4.30	3.20		
1R8	1.8	0.024	0.024	0.020	0.020			5.10	6.55		3.30	2.65	3.90	2.85		
2R2	2.2					0.017	0.017			13.60					4.20	3.35
2R4	2.4	0.031	0.031	0.023	0.023			4.35	5.50		2.80	2.35	3.60	2.60		
3R0	3.0					0.021	0.021			11.20					3.85	3.10
3R3	3.3	0.040	0.040	0.030	0.030			3.85	4.75		2.60	2.05	3.10	2.25		
3R9	3.9	0.046	0.046	0.034	0.034	0.023	0.023	3.40	4.15	9.15	2.50	1.95	2.90	2.15	3.75	2.95
4R7	4.7			0.039	0.039				3.85				2.70	2.00		
5R1	5.1	0.059	0.059			0.027	0.027	3.05		8.35	2.10	1.70			3.40	2.75
5R6	5.6			0.048	0.048				3.45				2.45	1.80		
6R2	6	0.069	0.069					2.80			1.90	1.50				
6R8	7	0.080	0.080	0.053	0.053	0.035	0.035	2.55	3.00	7.45	1.80	1.40	2.25	1.70	3.05	2.40
7R5	8			0.065	0.065				2.90				2.05	1.50		
8R2	8	0.095	0.095			0.039	0.039	2.35		7.00	1.65	1.30			2.90	2.25
9R1	9			0.070	0.070				2.75				1.95	1.45		
100	10	0.110	0.110	0.077	0.077	0.044	0.044	2.20	2.45	6.35	1.50	1.20	1.90	1.40	2.70	2.20
120	12	0.140	0.140	0.093	0.093	0.052	0.052	1.90	2.40	5.85	1.40	1.10	1.70	1.30	2.45	1.95
150	15	0.170	0.170	0.110	0.110	0.071	0.071	1.70	2.05	5.15	1.20	0.95	1.60	1.20	2.15	1.70
180	18	0.190	0.190	0.130	0.130	0.083	0.083	1.60	1.85	4.80	1.15	0.90	1.50	1.10	2.00	1.55
220	22	0.230	0.230	0.150	0.150	0.110	0.110	1.45	1.70	4.35	1.05	0.80	1.35	1.00	1.75	1.35
270	27	0.280	0.280	0.180	0.180	0.120	0.120	1.30	1.60	3.85	0.95	0.73	1.25	0.92	1.60	1.25
330	33	0.360	0.360	0.230	0.230	0.140	0.140	1.15	1.40	3.35	0.85	0.65	1.10	0.82	1.55	1.15
390	39	0.420	0.420	0.260	0.260	0.180	0.180	1.05	1.30	3.05	0.75	0.60	1.05	0.77	1.35	1.03
470	47	0.510	0.510	0.320	0.320	0.200	0.200	0.95	1.15	2.90	0.70	0.55	0.95	0.71	1.30	0.98
560	56			0.390	0.390	0.250	0.250		1.05	2.70			0.85	0.64	1.15	0.87
680	68			0.480	0.480	0.300	0.300		1.00	2.35			0.75	0.58	1.05	0.79
820	82			0.580	0.580	0.035	0.035		0.90	2.10			0.68	0.53	0.96	0.72
101	100			0.710	0.710	0.042	0.042		0.80	1.95			0.62	0.48	0.88	0.66
121	120			0.770	0.770	0.051	0.051		0.75	1.80			0.59	0.46	0.80	0.60
151	150			1.000	1.000	0.063	0.063		0.65	1.55			0.52	0.40	0.72	0.53
181	180					0.075	0.075			1.45					0.68	0.49

Notes: 1. Measurement Frequency for Inductance: 100kHz  
 2. DC saturation allowable current: Value of inductance decrease within 30%  
 3. Temperature rise allowable current: A rise in temperature of core surface is within 40°C  
 ※1. 4-3 or 2-1  
 ※2. 4-2 (3-1 short)

記事: 1. インダクタンス測定周波数: 100kHz  
 2. 直流重畳許容電流: インダクタンスの減少が30%以内の電流値  
 3. 温度上昇許容電流: コアの表面温度上昇が40°C以下の電流値  
 ※1: ④-③間 or ②-①間  
 ※2: ④-②間 (③-①間 ショート)

Inductance Range インダクタンス範囲

Tolerance	SQR8042CA	SQR8065CA	SQR1277CA
±35%(A)	1.3~3.9 $\mu\text{H}$	1.3~5.6 $\mu\text{H}$	2.2~6.8 $\mu\text{H}$
±30%(N)	5.1~8.2 $\mu\text{H}$	6.8~9.1 $\mu\text{H}$	8.2 $\mu\text{H}$
±20%(M)	10~47 $\mu\text{H}$	10~150 $\mu\text{H}$	10~180 $\mu\text{H}$

Parts Code 品番コード例

SQR8042CA	—	100	M
Type タイプ		Inductance Code インダクタンスコード	Tolerance 許容差



## ■ SQR80/12-CA series

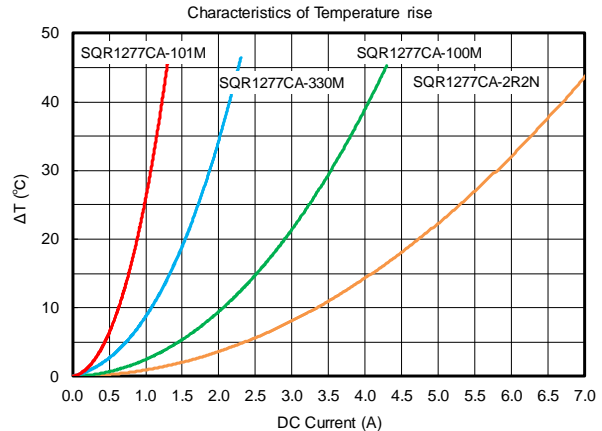
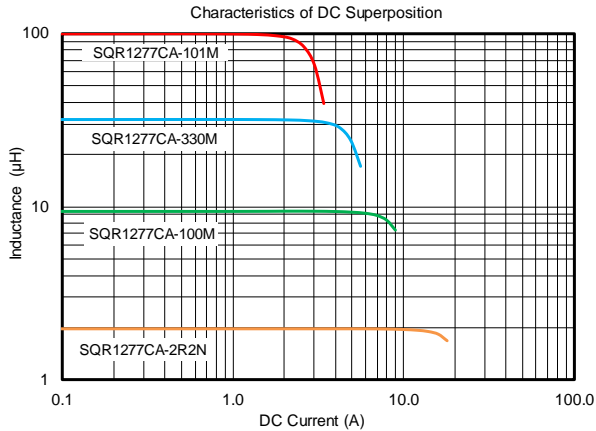
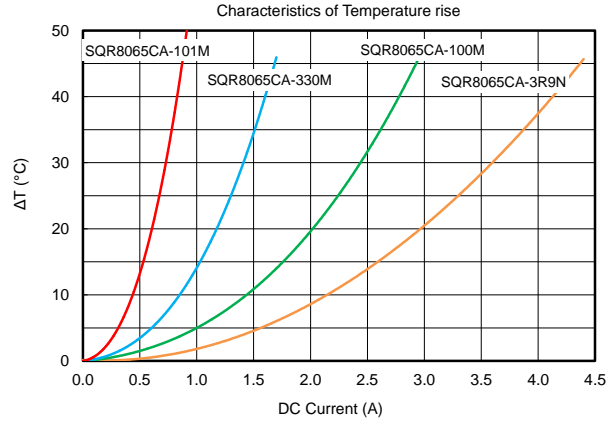
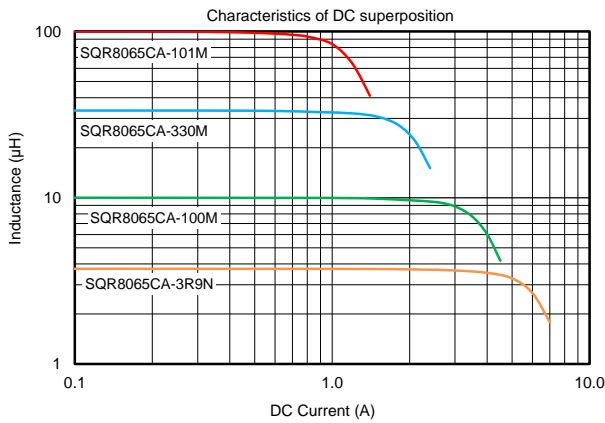
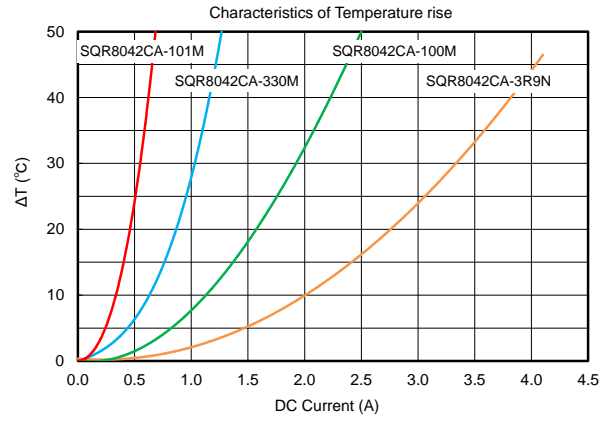
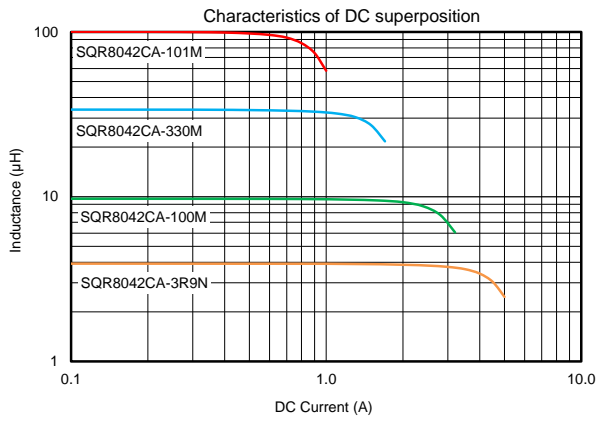

Notes: Graphs are based on typical values of each type, not specific values.

記事: 特性グラフは各タイプの代表値を基に作成しています。規格値ではありません。



\* 記載内容は、予告無く変更あるいは製造中止する場合があります。ご注文時は最新の情報をご確認願います。  
 \* Any products mentioned in this catalog are subject to any modification or termination without prior notice. Please check a latest information at placing a purchase order.  
 \* 記載製品のご使用に際しては、カタログ記載の『注意』をご確認願います。  
 \* Please refer to " DIRECTIONS " in the catalog for proper use of the products.

## Example circuit

【SEPIC Converter】

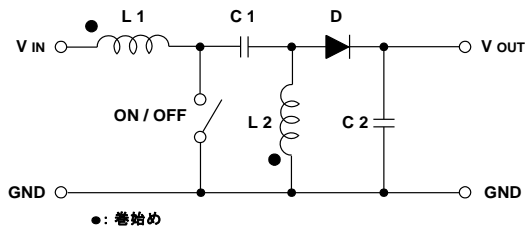

【ZETA Converter】

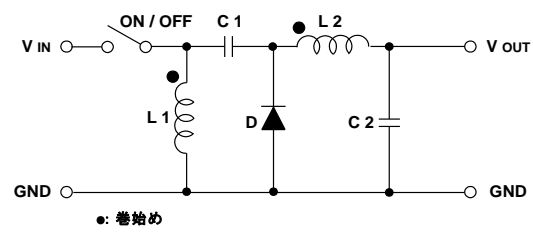

## Test Circuit 【SEPIC Converter】

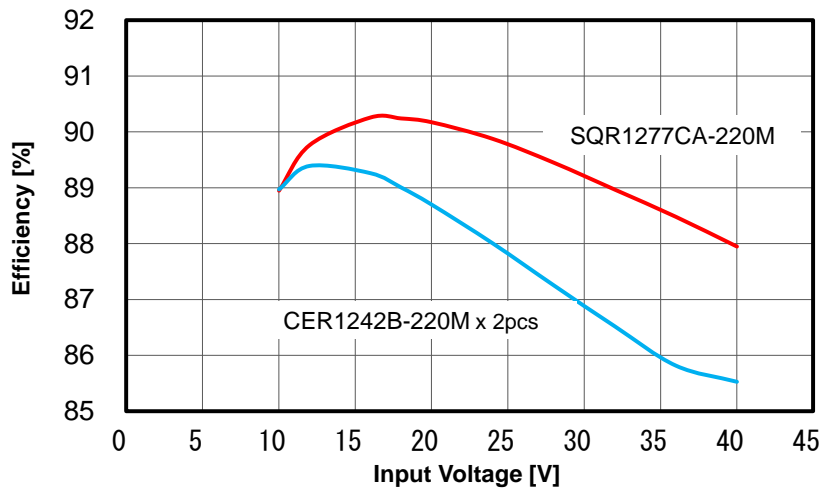
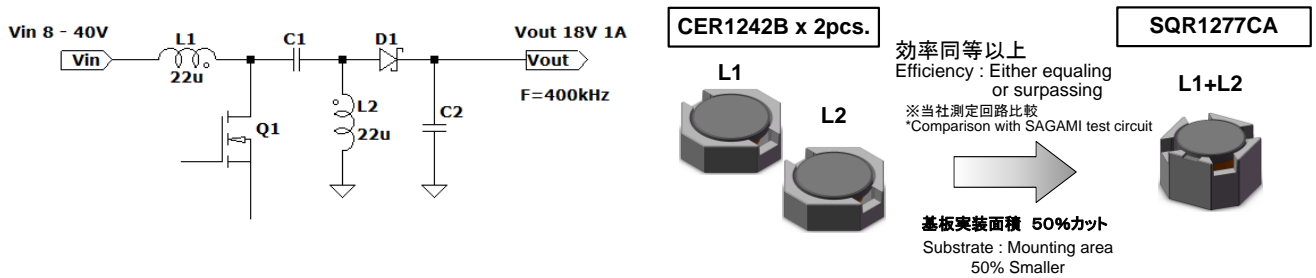

Part Number 品番	Inductance インダクタンス ( $\mu$ H)	DC Resistance 直流抵抗 ( $\Omega$ ) ④-③/②-①	DC saturation allowable current 直流重畳許容電流 (A)	Temperature rise allowable current 温度上昇許容電流 (A)	
				※1	※2
SQR1277CA-220M	22 $\pm$ 20%	0.11 max. (0.067/0.076)	4.35 (6.35)	1.75 (2.44)	1.35 (1.85)
CER1242B-220M	22 $\pm$ 20%	0.045 $\pm$ 30%	2.80 (3.70)	2.50 (3.40)	

Notes: 1. Measurement Frequency for Inductance: 100kHz  
2. Rated current: DC saturation allowable current or Temperature rise allowable current, whichever is smaller.  
a) DC saturation allowable current: Value of inductance decrease within 30% ( ) value of inductance decrease 30%.  
b) Temperature rise allowable current: A rise in temperature of core surface is within 40°C ( ) A rise in temperature of core surface is 40°C  
※1. 4-3 or 2-1  
※2. 4-2 (3-1 short)

記事: 1. インダクタンス測定周波数: 100kHz  
2. 定格電流: 直流重畳許容電流と温度上昇許容電流のいずれか小さい方の値  
a) 直流重畳許容電流: 初期インダクタンス値の-30%以内の電流値 ( )内は、初期インダクタンス値の-30%の電流値  
b) 温度上昇許容電流: コアの表面温度上昇が40°C以下の電流値 ( )内は、コアの表面温度上昇が40°Cの電流値  
※1: ④-③間 or ②-①間  
※2: ④-②間 (③-①間 ショート)

Notes: Graphs are based on typical values of each type, not specific values.

記事: 特性グラフは各タイプの代表値を基に作成しています。規格値ではありません。



## ■ Example circuit 1

### 【Flyback Converter】

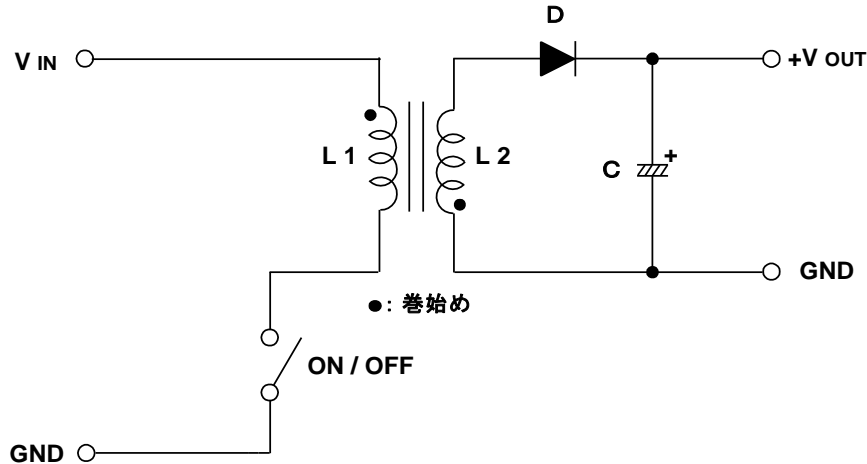

\* “絶縁型” DC/DCコンバータ回路を要する用途に最適。チョップ方式のDC/DCコンバータは、回路もシンプルな為小型基板のDC/DCコンバータとして多用されている。チョップ方式の様なDC/DCコンバータを非絶縁型と言うのに対して、上記の様なトランスを用いたタイプを絶縁型と言い、伝導ノイズの遮断や感電防止なども図れる。また、SQR1257C-N1517は、L1とL2のインダクタンス値がそれぞれ異なりながらも結合係数 0.98と理想的なトランスを実現。VIN>VOUTやVIN<VOUT、VIN>-VOUT、VIN<-VOUT など幅広いご要望に対して巻数アレンジが可能。

L1とL2のインダクタンス値が同じ仕様に関しては、標準品として幅広く取り揃えているが、SQR1257C-N1517の様なカタログに無い特別仕様に関しても対応可能。

\* This is suitable for the insulated DC/DC converter circuit board. Due to the simplicity of circuit, Chopper DC/DC converter is used frequently for small circuit board of DC/DC converter. The type of Chopper DC/DC converter is called non-insulated type and the circuit board which is used above type of transformer is called insulated type. It can shut the conductive noise and prevent electrical shock as well. Although our SQR1257C-N1517 indicate different inductance for L1 and L2, the coefficient of coupling realizes 0.98 as ideal figure of transformer. We would arrange the winding number for your request such as  $V_{in} > V_{out}$ ,  $V_{in} < V_{out}$ ,  $V_{in} > -V_{out}$  and  $V_{in} < -V_{out}$ . Regarding the specification which inductance of L1 and L2 is the same, we have variety of specifications as standard parts.

And we would try to support unique specification request such as that of SQR1257C-N1517 which is not on our catalogue.

	Part Number 品番	Inductance インダクタンス ( $\mu\text{H}$ )	DC Resistance 直流抵抗 ( $\Omega$ ) $\pm 30\%$	DC saturation allowable current 直流重畳許容電流 (A)	Temperature rise allowable current 温度上昇許容電流 (A)	
					※1	※2
④-③間	SQR1257C-N1517	21.0	0.08	3.6 (5.2)	1.75 (2.40)	1.15 (1.60)
②-①間		25.0	0.11	3.5 (4.8)	1.50 (2.10)	

Notes: 1. Measurement Frequency for Inductance: 100kHz  
 2. Rated current: DC saturation allowable current or Temperature rise allowable current, whichever is smaller.  
 a) DC saturation allowable current: Value of inductance decrease within 30%  
 ( ) value of inductance decrease 30%.  
 b) Temperature rise allowable current: A rise in temperature of core surface is within 40°C  
 ( ) A rise in temperature of core surface is 40°C  
 ※1. 4-3 or 2-1  
 ※2. 4-1 (3-2 short)

記事: 1. インダクタンス測定周波数: 100kHz  
 2. 定格電流: 直流重畳許容電流と温度上昇許容電流のいずれか小さい方の値  
 a) 直流重畳許容電流: 初期インダクタンス値の-30%以内の電流値  
 ( )内は、初期インダクタンス値の-30%の電流値  
 b) 温度上昇許容電流: コアの表面温度上昇が40°C以下の電流値  
 ( )内は、コアの表面温度上昇が40°Cの電流値  
 ※1: ④-③間 or ②-①間  
 ※2: ④-①間 (③-②間 ショート)



## ■ Example circuit 2

【Split-Rail Power Supply】

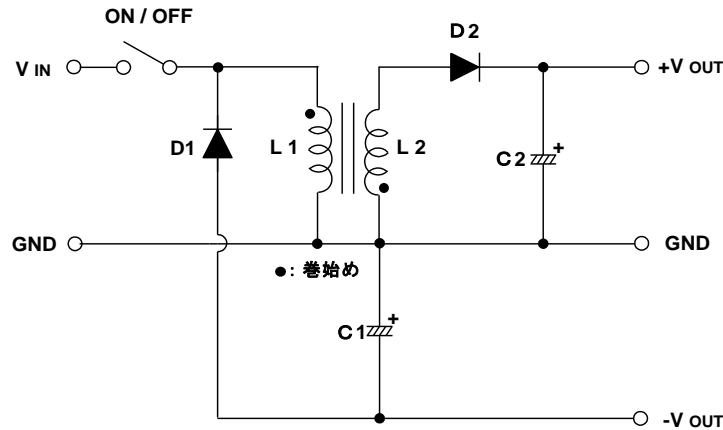

\* 特に電池駆動方式で、+と-出力電圧を要する用途に最適。±電源電圧レールをマッチングさせる事は、民生用や産業用アプリケーションなどには共通の要求として有り、特にオペアンプにとっては重要。

反転型降圧チョップ方式のインダクタを結合インダクタに置き換えてダイオードとコンデンサを追加すると、この電源回路から、それぞれ+と-の出力を取り出す事が出来る。また、SQR1257C-N1517は、出力電圧微調整対応の為、L1とL2のインダクタンス値がそれぞれ異なりながらも結合係数0.98と理想的なトランスを実現。L1とL2のインダクタンス値が同じ仕様に関しては、標準品として幅広く取り揃えているがSQR1257C-N1517の様なカタログに無い特別仕様に対しても対応可能。

\* This is suitable for the specification which needs + and - output voltage such as battery powered application. Matching +/- power supply voltage rail is common subject for consumer and industrial application, especially it is important operational amplifier.

Exchanging the inductor of inversion step down chopper into coupled inductor, and adding diode and capacitor realizes picking up each + and - output from power supply. Although our SQR1257C-N1517 indicate different inductance for L1 and L2 because of adjust of output voltage, coefficient of coupling realizes 0.98 as ideal figure of transformer. Regarding the specification which inductance of L1 and L2 is the same, we have variety specifications as standard parts. And we would try to support unique specification request such as that of SQR1257C-N1517 which is not on our catalogue.

	Part Number 品番	Inductance インダクタンス ( $\mu\text{H}$ )	DC Resistance 直流抵抗 ( $\Omega$ ) $\pm 30\%$	DC saturation allowable current 直流重畳許容電流 (A)	Temperature rise allowable current 温度上昇許容電流 (A)	
					※1	※2
④-③間	SQR1257C-N1517	21.0	0.08	3.6 (5.2)	1.75 (2.40)	1.15 (1.60)
②-①間		25.0	0.11	3.5 (4.8)	1.50 (2.10)	

Notes: 1. Measurement Frequency for Inductance: 100kHz  
 2. Rated current: DC saturation allowable current or Temperature rise allowable current, whichever is smaller.  
 a) DC saturation allowable current: Value of inductance decrease within 30%  
 ( ) value of inductance decrease 30%.  
 b) Temperature rise allowable current: A rise in temperature of core surface is within 40°C  
 ( ) A rise in temperature of core surface is 40°C  
 ※1. 4-3 or 2-1  
 ※2. 4-1 (3-2 short)

記事: 1. インダクタンス測定周波数: 100kHz  
 2. 定格電流: 直流重畳許容電流と温度上昇許容電流のいずれか小さい方の値  
 a) 直流重畳許容電流: 初期インダクタンス値の-30%以内の電流値  
 ( )内は、初期インダクタンス値の-30%の電流値  
 b) 温度上昇許容電流: コアの表面温度上昇が40°C以下の電流値  
 ( )内は、コアの表面温度上昇が40°Cの電流値  
 ※1: ④-③間 or ②-①間  
 ※2: ④-①間 (③-②間 ショート)

