

CER8065V

New Products

RoHS

AEC-Q200



■ Features

- SMD magnetic shielded type of power inductor.
- 400V High withstand voltage product
- Suitable for DC-DC converter with high voltage input

■ Magnetic structure

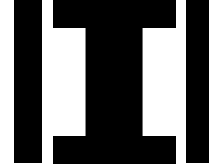

Operating Temperature Range : -40 °C~ +150 °C(include self-heating)

Weight : 1.4 g

■ Application

- Power supply for microcomputers in home appliances
- Intelligent House(IoT,Bluetooth)
- Power supply circuit for HEV / EV

■ Dimensions

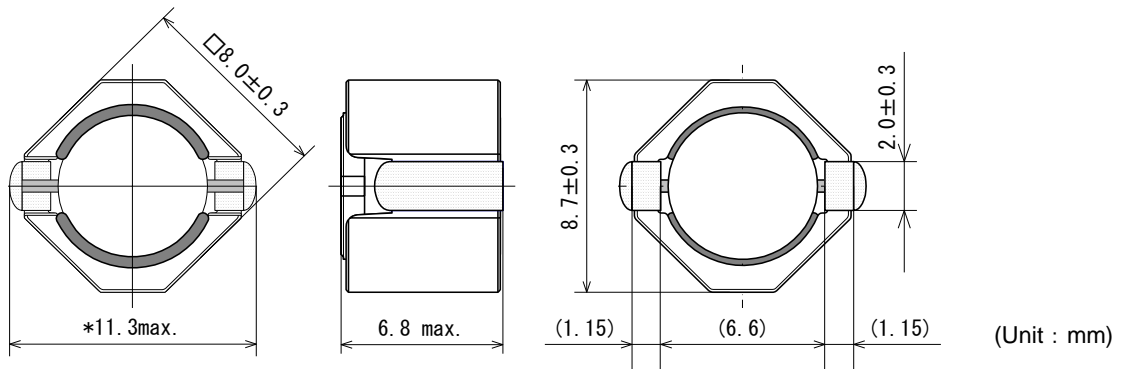

■ Recommended Land Pattern

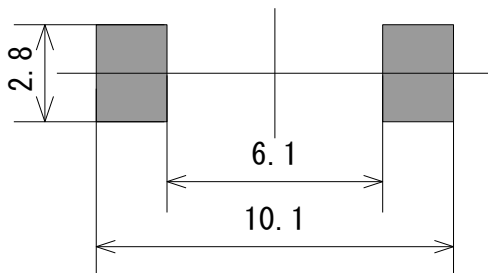

SAGAMI ELEC CO., LTD.
<https://www.sagami-elec.co.jp>

10-30, Ichibashimo-cho, Tsurumi-ku, Yokohama, Kanagawa 230-0024, Japan
 Over Seas Sales Dept. TEL : +81 45 511 3141, E-mail : ossg@sagami-elec.co.jp
 Engineering Dept. TEL : +81 45 521 4543

⚠ The contents of this catalogue are subject to change without notice.

■ Specifications

SAGAMI Part No.	Inductance (μ H)	DCR Resistance (Ω) $\pm 30\%$	Rated current			
			DC saturation allowable current (A)		Temperature rise allowable current (A)	
			Spec.	Typical	Spec.	Typical
CER8065V-101M	100 $\pm 20\%$	0.280	1.20	1.65	0.850	1.19
CER8065V-151M	150 $\pm 20\%$	0.390	1.00	1.35	0.720	1.00
CER8065V-221M	220 $\pm 20\%$	0.530	0.820	1.10	0.610	0.860
CER8065V-331M	330 $\pm 20\%$	0.800	0.680	0.930	0.500	0.700
CER8065V-471M	470 $\pm 20\%$	1.32	0.570	0.780	0.380	0.540
CER8065V-681M	680 $\pm 20\%$	1.82	0.480	0.640	0.320	0.460
CER8065V-102M	1000 $\pm 20\%$	2.60	0.380	0.530	0.270	0.380

- Inductance Measuring Condition : 100kHz,1V
- Rated current : DC saturation allowable current or Temperature rise allowable current, whichever is smaller.
 1. DC saturation allowable current (Spec.) : value of inductance decrease within 30%.
DC saturation allowable current (Typical) : value of inductance decrease 30%.
 2. Temperature rise allowable current (Spec.) : A rise in temperature of core surface is within 40°C.
Temperature rise allowable current (Typical) : A rise in temperature of core surface is 40°C.



SAGAMI ELEC CO., LTD.
<https://www.sagami-elec.co.jp>

10-30, Ichibashimo-cho, Tsurumi-ku, Yokohama, Kanagawa 230-0024, Japan
 Over Seas Sales Dept. TEL : +81 45 511 3141, E-mail : ossg@sagami-elec.co.jp
 Engineering Dept. TEL : +81 45 521 4543

The contents of this catalogue are subject to change without notice.

DC bias characteristics vs Temperature Rise Graph

■ L(25°C) ■ ΔT

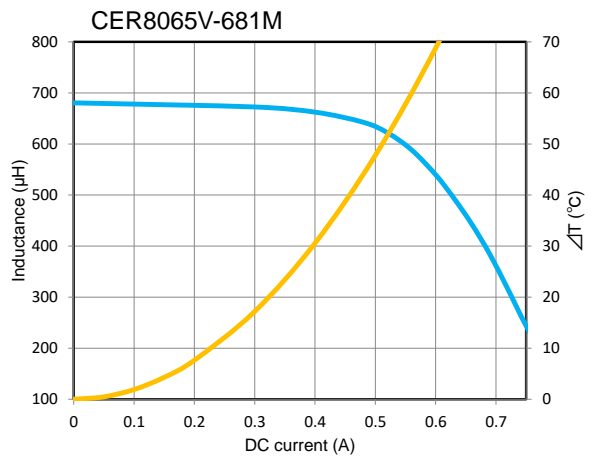
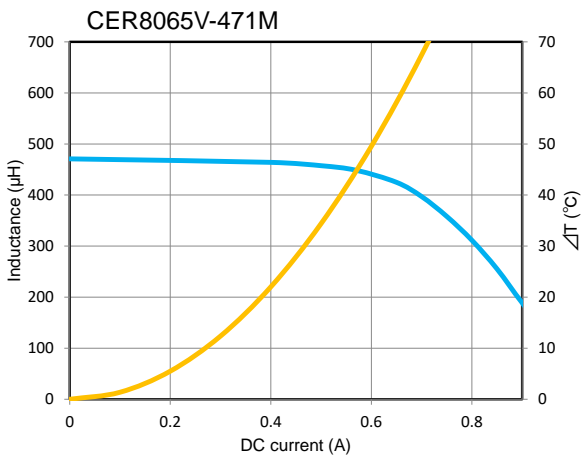
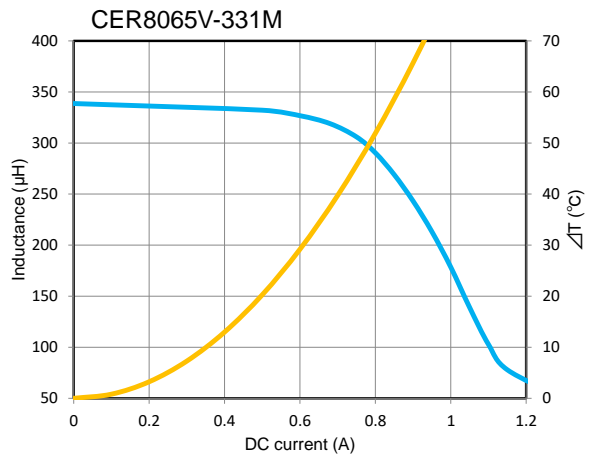
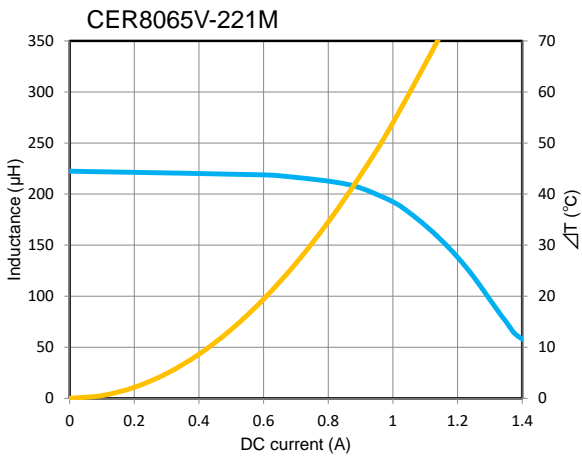
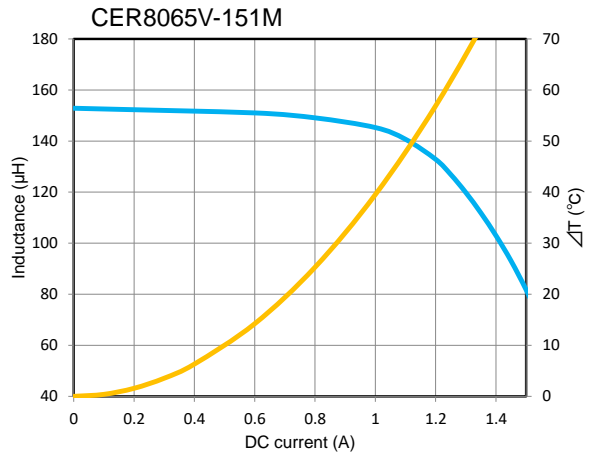
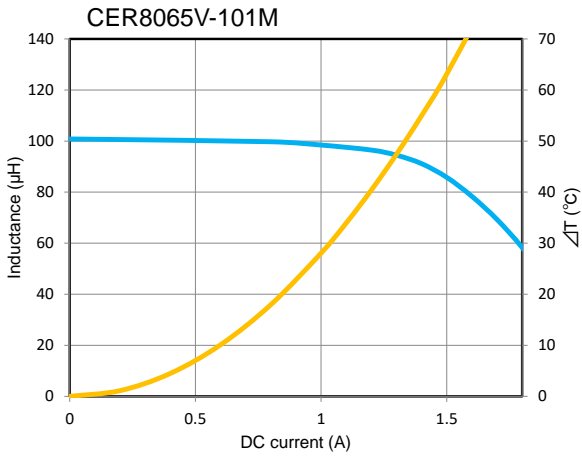

DC bias characteristics vs Temperature Rise Graph



L(25°C)



ΔT

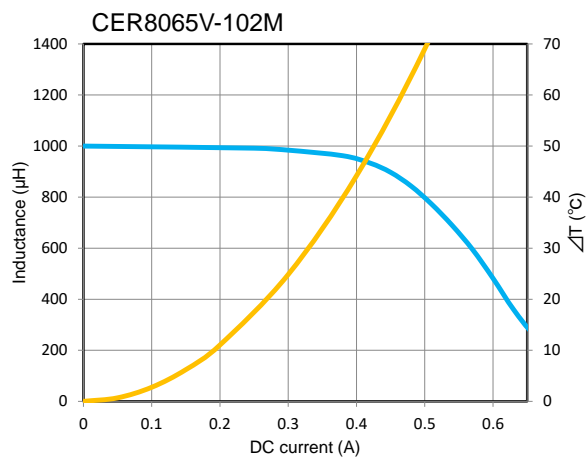

サガミ エレク株式会社
SAGAMI ELEC CO., LTD.